



# Alloy Film Low Resistance Chip Resistors (RBL Series)

Document No	TRBL-XX0S001K
Issued date	2014/06/12
Page	1/9

## 1. Scope :

The specification applies for the RBL Series (0603 ~ 2512) of alloy film low resistance chip resistors made by TA-I and the resistance range between 10mΩ and 91mΩ.

## 2. Features:

- ◆ Low Resistance and High Accuracy Resistor for Current Detection
- ◆ Large Electrode (All series)
- ◆ Good Performance for Heat Dissipation
- ◆ High Purity Alumina Substrate for High Power Dissipation
- ◆ Pb-free to Meet RoHS Requirements

## 3. Applications:

- ◆ Power Management Applications
- ◆ Switching Power Supply
- ◆ DC-DC Converter, Battery Pack, Charger, Adaptor
- ◆ Portable Instruments (PDA and Cell Phone)
- ◆ Voltage Regulation Module (VRM)
- ◆ Computer

## 4. Type Designation:

RBL	10	F	T	R030
Low Ohm Chip Resistors	Size/Power Rating	Tolerance Of Resistance at 25°C	Packaging	Nominal Resistance
	06:0603:0.25W 10:0805:0.5W 12:1206:0.5W 20:2010:0.75W 25:2512:1W	F:±1.0% G:±2.0% J:±5.0%	T: Paper E: Embossed	R030 : 30mΩ



# Alloy Film Low Resistance Chip Resistors (RBL Series)

Document No	TRBL-XX0S001K
Issued date	2014/06/12
Page	2/9

## 5. Dimensions:

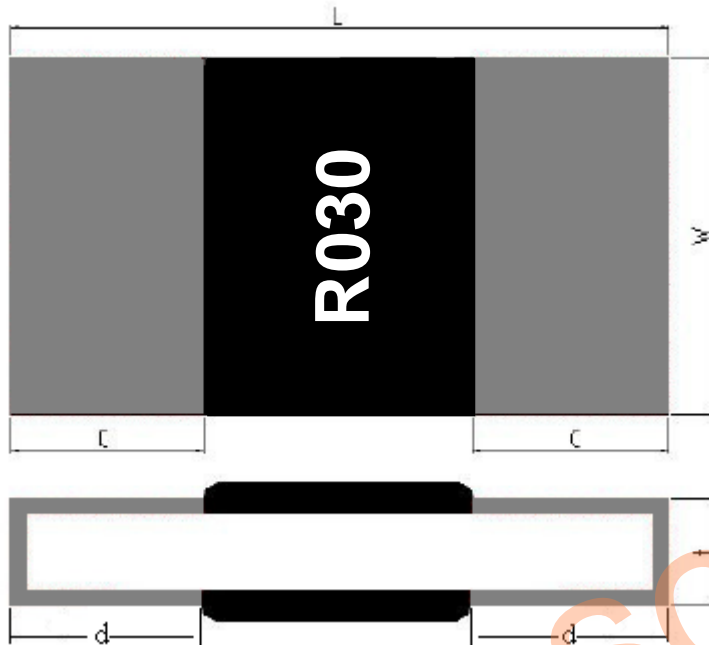

Unit: mm

Item	L	w	c	d	t
RBL06	1.60±0.1	0.90±0.1	0.47±0.1	0.47±0.1	0.50±0.1
RBL10	2.00±0.1	1.30±0.1	0.55±0.1	0.55±0.1	0.62±0.1
RBL12	3.10±0.1	1.60±0.1	1.10±0.2	1.10±0.2	0.62±0.2
RBL20	5.00±0.2	2.60±0.2	1.80±0.2	1.80±0.2	0.62±0.2
RBL25	6.30±0.2	3.20±0.2	2.0±0.3	2.0±0.3	0.65±0.2



# Alloy Film Low Resistance Chip Resistors (RBL Series)

Document No	TRBL-XX0S001K
Issued date	2014/06/12
Page	3/9

## 6. Electrical Characteristics

Chip Size	Power Rating	TCR (ppm/°C)	Resistance Range (mΩ)			Operating Temp. Range
			F : ±1%	G : ±2%	J : ±5%	
0603	0.25W	± 200	10~20			-55°C~ +155°C
		± 100	21~91			
0805	0.5W	± 200	10~20			
		± 100	21~91			
1206	0.5W	± 200	10~20			
		± 100	21~91			
2010	0.75W	± 200	10~20			
		± 100	21~91			
2512	1W	± 200	10~20			
		± 100	21~91			

## 7. Derating Curve

For resistors operated at ambient temperature over 70°C, power rating shall be derated in accordance with figure 1.

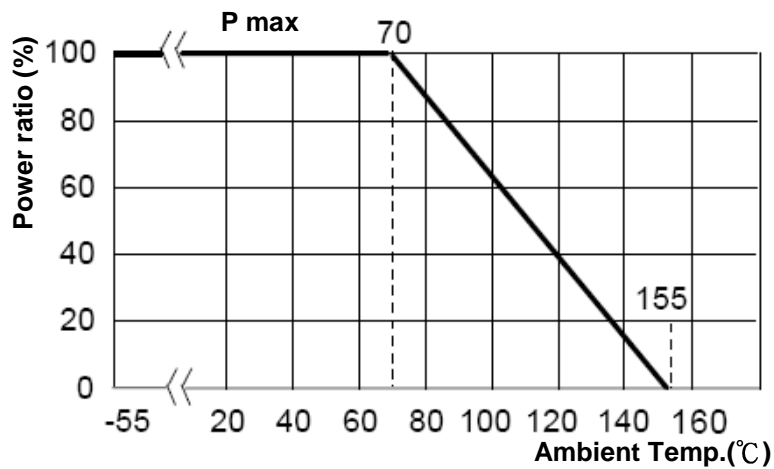

Figure 1



# Alloy Film Low Resistance Chip Resistors (RBL Series)

Document No	TRBL-XX0S001K
Issued date	2014/06/12
Page	4/9

## 8. Reliability Tests:

Test Item	Reference standard	Condition of Test	Test Limits
Temperature Coefficient of Resistance	IEC60115-1-4.8 JIS-C5201-1-4.8	-55 ~ +125°C	Refer to paragraph 6
Short Time Overload	IEC60115-1-4.13 JIS-C5201-1-4.13	2.5 X rated voltage, 5s	± (1%+0.001 Ω)
Load Life	IEC60115-1-4.25.1 JIS-C5201-1-4.25.1	1000 hours at rated power , 70°C, 1.5hours "ON", 0.5hour "OFF"	± (2%+0.001 Ω)
Load Life with Humidity	IEC60115-1-4.24 JIS-C5201-1-4.24	1000 hours at rated power , 40 ± 2°C, 90~95% RH 1.5hours "ON", 0.5hour "OFF"	± (2%+0.001 Ω)
Rapid Change of Temperature	IEC60115-1-4.19 JIS-C5201-1-4.19	-55°C (30 min. ) / +125 °C (30 min.) 5 cycles	± (1%+0.001 Ω)
Resistance to Soldering Heat	IEC60115-1-4.18 JIS-C5201-1-4.18	270 ± 5°C solder , 10 ± 1 sec dwell .	± (1%+0.001 Ω)
Solderability	IEC60115-1-4.17 JIS-C5201-1-4.17	245±5°C solder, 2±0.5 sec dwell. Solder : Sn96.5 / Ag3.0 / Cu0.5	At least 95% of surface area of electrode shall be covered with new solder.
Robustness of Termination (Bending Strength)	IEC60115-1-4.33 JIS-C5201-1-4.33	RBL06、10、12 : 3mm deflection RBL20、25 : 2mm deflection	± (1%+0.001Ω)
Resistance to Dry Heat	IEC60115-1-4.23.2 JIS-C5201-1-4.23.2	125 ± 5°C for 96 ± 4hrs	± (1%+0.001 Ω)

## 9. Marking:

From 0805 to 2512:

Resistance value is expressed by 4 digits, the first "R" means decimal point and the other digits represent for the normal resistance in Ω.

eg., 15mΩ= R015

For 0603: No Marking.



# Alloy Film Low Resistance Chip Resistors (RBL Series)

Document No	TRBL-XX0S001K
Issued date	2014/06/12
Page	5/9

## 10. Taping & Reel

### 10.1 Taping Dimensions

#### 10.1.1 4 mm pitch paper

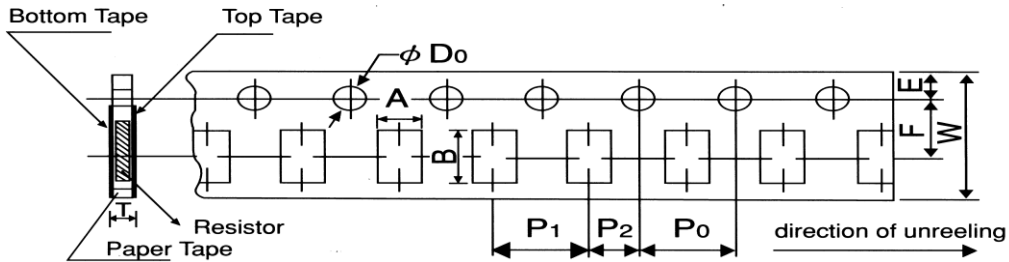

Packing	Type	A	B	W	F	E	P <sub>1</sub>	P <sub>2</sub>	P <sub>0</sub>	D <sub>0</sub>	T
Paper Tape	RBL06	1.1±0.1	1.9±0.1	8.0±0.2	3.5±0.05	1.75±0.1	4.0±0.1	2.0±0.1	4.0±0.1	Φ 1.5	0.64±0.1
	RBL10	1.6±0.15	2.4±0.2								+0.1 -0.1
	RBL12	2.0±0.15	3.6±0.2								0.84±0.1

UNIT: mm

#### 10.1.2 4 mm pitch Emboss

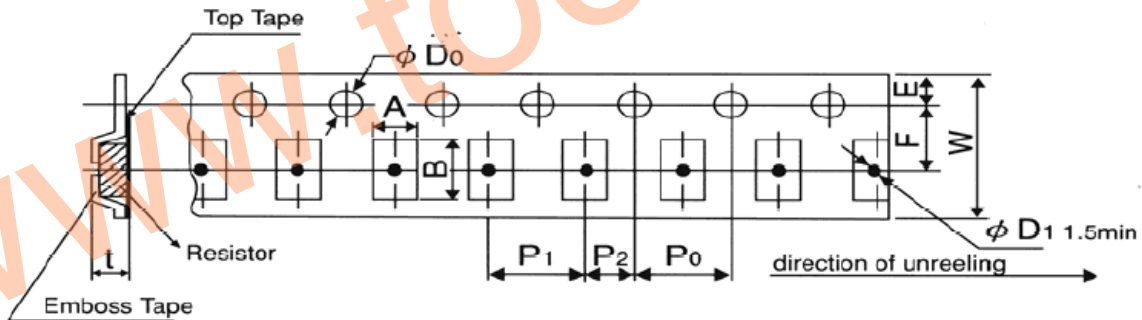

Packing	Type	A	B	W	F	E	P <sub>1</sub>	P <sub>2</sub>	P <sub>0</sub>	D <sub>0</sub>	T
Emboss	RBL20	2.8±0.2	5.3±0.2	12.0±0.2	5.5±0.05	1.75±0.1	4.0±0.1	2.0±0.05	4.0±0.05	+0.1 Φ 1.5 -0.1	0.85±0.15
	RBL25	3.6±0.2	6.9±0.2								

UNIT: mm



# Alloy Film Low Resistance Chip Resistors (RBL Series)

Document No	TRBL-XX0S001K
Issued date	2014/06/12
Page	6/9

## 10.2 Reel Specifications

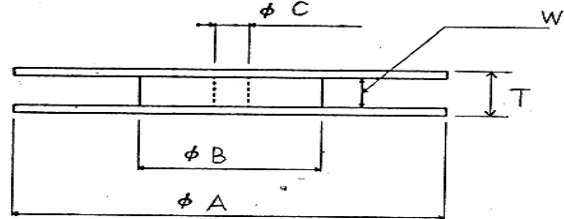
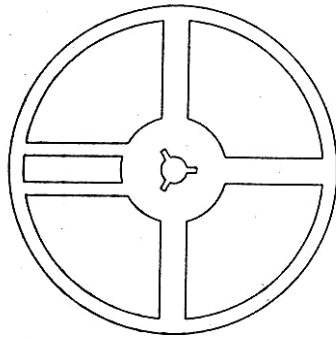

UNIT: mm

Type	ΦA	ΦB	ΦC	W	T
RBL06 RBL10 / 12	178.0 ±2.0	60.0 ±1.0	13.0 ±1.0	9.0 ±1.0	11.4 ±1.0
RBL20 / 25				13.0 ±1.0	15.5 ±1.0

## 10.3 Peel – off force :

Peel – off force of paper and blister tape is in accordance with “JIS ”  
that is , 0.1 to 0.7 N at a peel-off speed of 300 mm / minute.

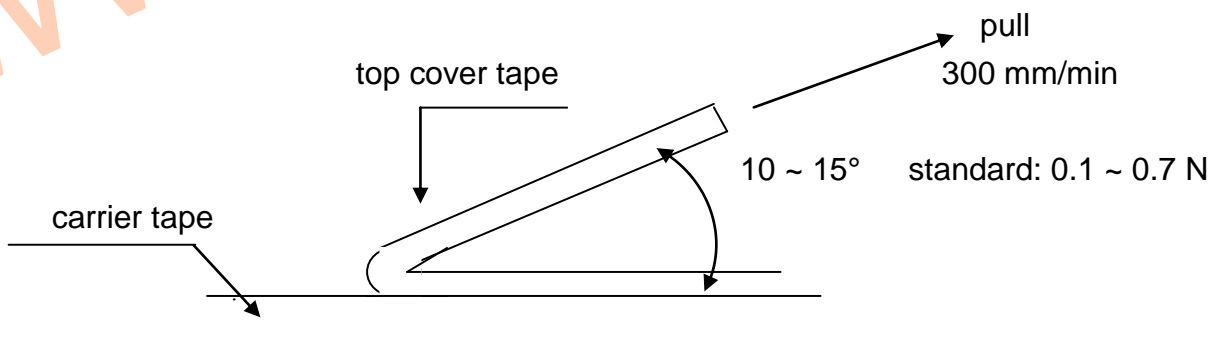

UNIT: mm



# Alloy Film Low Resistance Chip Resistors (RBL Series)

Document No	TRBL-XX0S001K
Issued date	2014/06/12
Page	7/9

## 11. Label

### 11.1 Normal Products :

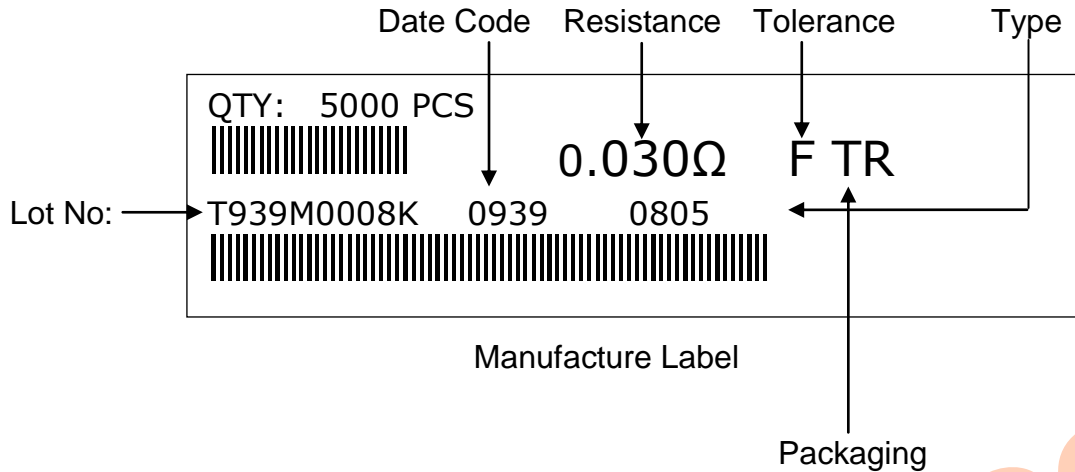

## 12. Recommended land patterns

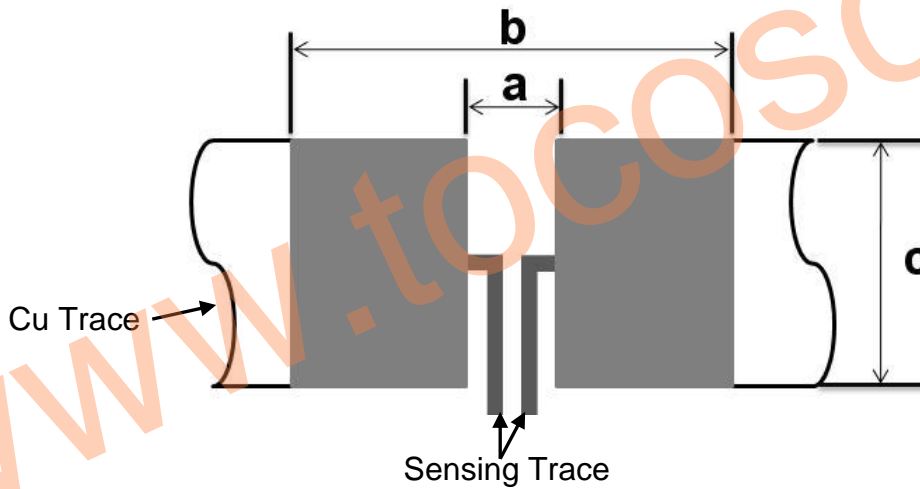

Type	Size	Land pattern		
		Dimension ( mm )		
		a	b	c
RBL	06 (0603 )	0.7±0.10	3.3±0.10	1.4±0.10
RBL	10 (0805 )	0.7±0.20	3.3±0.20	1.7±0.20
RBL	12 (1206 )	0.7±0.20	5.1±0.20	2.5±0.20
RBL	20 (2010 )	1.0±0.20	6.1±0.20	3.5±0.20
RBL	25 (2512 )	1.0±0.20	7.5±0.20	4.2±0.20

## 13. ECN

Engineering Change Notice: The customer will be informed with ECN if there is significant modification on the characteristics and materials described in Approval Sheet.



# Alloy Film Low Resistance Chip Resistors (RBL Series)

Document No	TRBL-XX0S001K
Issued date	2014/06/12
Page	8/9

### 14. Storage Conditions:

Temperature: 5°C~35°C, Humidity: 40%~75%

### 15. Shelf Life:

2 years from manufacturing date.

### 16. Recommend IR – Reflow profile : (solder : Sn96.5 / Ag3 / Cu0.5)

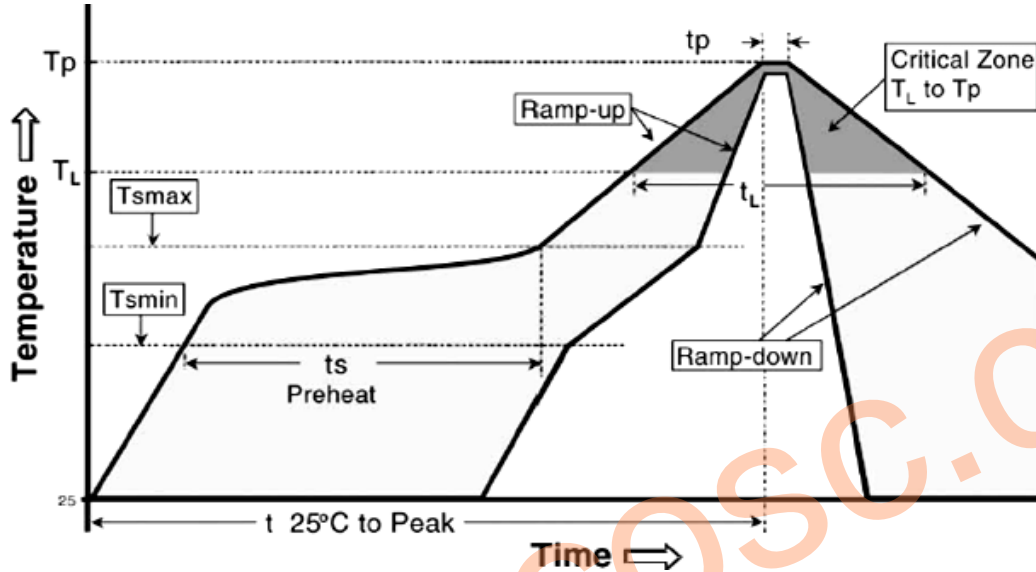

Profile Feature	Lead (Pb)-Free Assembly
Average ramp-up rate ( $T_{smax}$ to $T_p$ )	3°C / second max.
Preheat - Temperature Min ( $T_{smin}$ ) - Temperature Max ( $T_{smax}$ ) - Time ( $T_{smin}$ to $T_{smax}$ ) ( $t_s$ )	150°C 200°C 60 -150 seconds
Time maintained above : - Temperature ( $T_L$ ) - Time ( $t_L$ )	217°C 60-120 seconds
Peak Temperature ( $T_p$ )	260°C
Time within $\begin{matrix} +0^\circ\text{C} \\ -5^\circ\text{C} \end{matrix}$ of actual Peak Temperature ( $t_p$ ) <sup>2</sup>	10 seconds
Ramp-down Rate	6°C/second max.
Time 25°C to Peak Temperature	8minutes max.

Alloyed Re-flow times : 3 times

Remark : To avoid discoloration phenomena of chip on terminal electrodes,  
please use N2 Re-flow furnace





**Alloy Film  
Low Resistance Chip Resistors  
(RBL Series)**

Document No	TRBL-XX0S001K
Issued date	2014/06/12
Page	9/9

**17. Manufacturing Country & City :**

TA-I TECHNOLOGY CO., LTD. ( Taiwan– Tao Yuan )

Tel: (+886) 3-3246169 Fax : (+886) 3-3246167

**Associated companies :**

(1)TA-I TECHNOLOGY ( SU ZHOU ) CO., LTD. ( China – Su Zhou)

Tel :(+86) 512-63457879 Fax : (+86) 512-63457869

(2) TA-I TECHNOLOGY ELECTRONIC (DONGGUAN ) CO., LTD. ( China –Dongguan )

Tel : (+86) 769-8339-4790~3 Fax : (+86) 769-8339-4794

(3) FORTUNE TASK RESISTOR FACTORY ( China – Dongguan )

Tel : (+86) 769-8339-4790~3 Fax : (+86) 769-8339-4794

(4) TAI OHM ELECTRONICS ( M ) SDN. BHD. ( Malaysia – Penang )

Tel :(+60) 4- 3900480 Fax : (+60) 4-3901481

(5) TAI ELECTRONICS Indonesia ( Indonesia – Jakarta )

Tel :62-21-89830123 Fax : 62-21-89830703