

◆贴片型 产品型号体系 / CHIP TYPE PART NUMBER

额定电压 Rated Voltage		系列名称 Series		静电容量 Capacitance		静电容量允许差 Capacitance Tolerance		副记号 Option ※1	铝壳尺寸 Case Size
Rated Voltage(Vdc)	Code	Cap.(μF)	Code	Tolerance	Code			DxL	
6.3	6.3	4.7	4R7	±20%	M			4×6.1 8×10.5 16×21.5	
10	10	220	220						
25	25	3300	3300						
100	100								

在订货时, 请注明额定电压、系列名称、静电容量、铝壳尺寸的信息。
Please indicate the above information, when ordering.

例) : Example
35 TZV 330 M 10×10.5

※1 副记号: 标准品为空白。
Option : Standard item is blank.

◆引线型 产品型号体系 / RADIAL LEAD TYPE PART NUMBER

额定电压 Rated Voltage		系列名称 Series		静电容量 Capacitance		静电容量允许差 Capacitance Tolerance		副记号 Option ※2	引线加工记号 Lead Forming ※3	铝壳尺寸 Case Size
Rated Voltage(Vdc)	Code	Cap.(μF)	Code	Tolerance	Code			DxL		
6.3	6.3	0.1	0R1	±20%	M			5×11 10×12.5 12.5×40		
10	10	0.47	0R47							
25	25	1	1							
100	100	10	10							
		1000	1000							

在订货时, 请注明额定电压、系列名称、静电容量、引线加工、铝壳尺寸的信息。
Please indicate the above information, when ordering.

例) : Example
 ·长引线品 Long lead type 50 PX 2R2 M EFC 5×11
 ·编带品 Taping type 35 ZLJ 220 M TA 8×16

※2 副记号: 请确认各系列的页面。

Option : Please confirm each series page.

※3 引线加工记号: 请参照编带规格及引线加工规格的项目。

Lead Forming : Please refer to TAPING SPECIFICATIONS and LEAD CUTTING FORMING SPECIFICATIONS.

包装规格 / PACKAGING SPECIFICATION

◆ 引线端子型 / RADIAL LEAD TYPE

Q'ty (pcs)

产品尺寸 SIZE (mm)	长引线品 LONG LEAD		引线加工品 LEAD FORMING		编带品 TAPING	
	散装 BULK PACKAGE	盒装 ALIGNED PACKAGE	散装 BULK PACKAGE	盒装 ALIGNED PACKAGE		
	φ4	4×5	5,000	—		5,000
	4×7	5,000	—	5,000	—	2,000
φ5	5×5	5,000	—	5,000	—	2,000
	5×7	5,000	—	5,000	—	2,000
φ6.3	5×11	3,000	—	5,000	—	2,000
	6.3×5	3,000	—	5,000	—	2,000
	6.3×7	3,000	—	5,000	—	2,000
	6.3×11	2,000	—	3,000	—	2,000
φ6.3	6.3×14	2,000	—	3,000	—	2,000
	6.3×25	1,000	—	1,000	—	—
	6.3×30	1,000	—	1,000	—	—
	6.3×40	1,000	—	1,000	—	—
	6.3×50	1,000	—	1,000	—	—
	φ8	8×5	3,000	—	5,000	—
8×7		3,000	—	5,000	—	1,000
8×7.5		2,000	—	2,000	—	1,000
8×9		2,000	—	2,000	—	1,000
8×10.8		2,000	—	2,000	—	1,000
8×11.5		2,000	—	2,000	—	1,000
8×16		1,000	—	1,000	—	1,000
8×20		1,000	—	1,000	—	1,000
8×23		1,000	—	1,000	—	1,000
8×25		—	500	—	500	—
8×30		—	500	—	500	—
8×35		—	500	—	500	—
8×40		—	500	—	500	—
8×45		—	500	—	500	—
8×50	—	500	—	500	—	
8×55	—	500	—	500	—	
8×60	—	500	—	500	—	
φ10	10×9	1,000	—	1,000	—	500
	10×10	1,000	—	1,000	—	500
	10×12.5	1,000	—	1,000	—	500
	10×16	1,000	—	1,000	—	500
	10×20	1,000	—	1,000	—	500
	10×23	1,000	—	1,000	—	500
	10×25	1,000	500	1,000	500	500
	10×28	1,000	500	1,000	500	500
	10×30	—	500	—	500	—
	10×35	—	500	—	500	—
	10×40	—	500	—	500	—
	10×45	—	500	—	500	—
	10×50	—	500	—	500	—
	10×55	—	500	—	500	—
10×60	—	500	—	500	—	

产品尺寸 SIZE (mm)	长引线品 LONG LEAD		引线加工品 LEAD FORMING		编带品 TAPING
	散装 BULK PACKAGE	盒装 ALIGNED PACKAGE	散装 BULK PACKAGE	盒装 ALIGNED PACKAGE	
	φ12.5	12.5×16	1,000	—	
12.5×20		1,000	500	1,000	500
12.5×25		1,000	500	1,000	500
12.5×30		600	500	600	500
12.5×35		600	500	600	500
12.5×40		600	500	600	500
12.5×45		—	500	—	500
12.5×50		—	500	—	500
12.5×55		—	500	—	500
12.5×60		—	500	—	500
φ14.5	14.5×20	—	500	—	500
	14.5×25	—	500	—	500
	14.5×30	—	500	—	500
	14.5×31.5	—	500	—	500
	14.5×35	—	500	—	500
	14.5×40	—	500	—	500
φ16	14.5×45	—	500	—	500
	14.5×50	—	500	—	500
	16×16	600	—	600	400
	16×20	600	200	600	400
	16×25	600	200	600	400
	16×30	—	200	—	200
	16×31.5	—	200	—	200
	16×35	—	200	—	200
	16×35.5	—	200	—	200
	16×40	—	200	—	200
φ18	16×45	—	200	—	200
	16×50	—	200	—	200
	18×16	500	—	—	200
	18×20	500	200	—	200
	18×25	500	200	—	200
	18×30	—	200	—	200
	18×31.5	—	200	—	200
	18×35	—	200	—	200
	18×35.5	—	200	—	200
	18×40	—	200	—	200

• 包装单位存在与上述相异的情况。

There are some differences between actual package quantity and above list.

• 关于散装与盒装并记的尺寸，以盒装作为出口用的标准。

For the sizes stated both bulk and aligned package, aligned package is standard for exporting carton.

◆编带规格 / TAPING SPECIFICATIONS

◆纵向引线形(04形)编带形状尺寸图 / DIMENSIONS

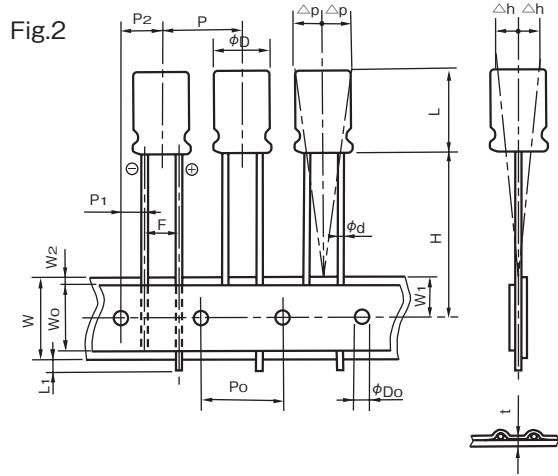
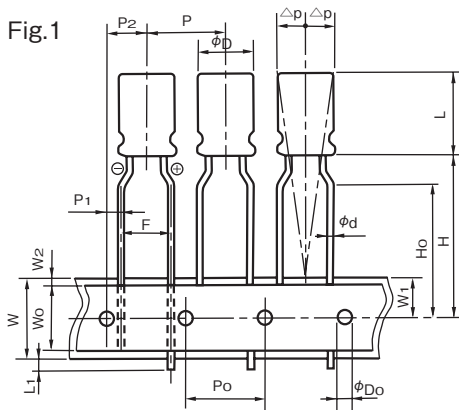

◆规格表 / SPECIFICATION TABLE

(mm)

项 目 Items	记号 Code	5mm Height		7mm or 7.5mm Height				允许差 Tolerance
		$\phi 4 \sim \phi 8$		$\phi 4 \sim \phi 6.3$	$\phi 4 \sim \phi 6.3$	$\phi 8$		
引线加工记号 Taping code		T5	TZ	T5	TZ	TA	T7	
形状尺寸图 Applicable Fig. No.		Fig.2	Fig.1	Fig.2	Fig.1	Fig.1	Fig.2	
引线直径 Dia. of lead	ϕd	0.45		0.45				± 0.05
主体高度 Height of body	L	6.5		8.5				MAX
主体间距 Distance from center to center of next body	P	12.7		12.7				± 1.0
穿孔间距 Distance from center to center of next driving hole	P_0	12.7		12.7				± 0.2
穿孔与引线间距 Distance between center of driving hole and lead	P_1	5.1	3.85	5.1	3.85	4.6	± 0.5	
穿孔与主体间距 Distance between center of driving hole and body	P_2	6.35		6.35				± 1.0
引线间距 Pitch of lead	F	2.5	5.0	2.5	5.0	3.5	$+0.8$ -0.2	
衬纸宽度 Width of mounting tape	W	18.0		18.0				± 0.3
胶带宽度 Width of adhesive tape	W_0	5.0		5.0				MIN
穿孔与衬纸间距 Distance between center of driving hole and mounting tape edge	W_1	9.0		9.0				± 0.5
胶带与衬纸间距 Max. allowable distance between mounting and adhesive tape edges	W_2	1.5		1.5				MAX
主体下方位置 Distance between center of driving hole and bottom of body	H	17.5		17.5		20.0		± 0.75
引线弯曲高度 Distance between center of driving hole and clinch part of lead	H_0	—	16.0	—	16.0		—	± 0.5
引线头 End of lead	L_1	0.5		0.5				MAX
穿孔直径 Dia. of driving hole	ϕD_0	4.0		4.0				± 0.2
主体倾斜度 Off alignment of body top	$\triangle h$	1.0		1.0				MAX
主体倾斜度 Off alignment of body top	$\triangle p$	1.0		1.0				MAX
编带总厚度 Sum of thickness for mounting and adhesive tape without lead dia	t	0.6		0.6				± 0.3
包装数量(个) Quantity (pcs)		2000 ($\phi 8$:1000)						

Fig.3

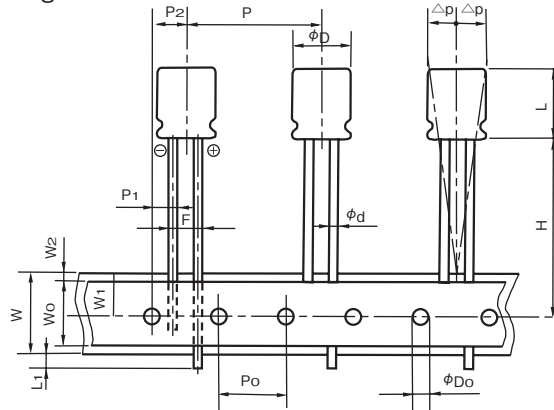

◆规格表 / SPECIFICATION TABLE

(mm)

项 目 Items	记号 Code	9mm or more Height						※ 允许差 Tolerance		
		φ5, φ6.3	φ8	φ10	φ12.5	φ16	φ18			
引线加工记号 Taping code		T1	TA	TA	T7	T8	G4	GC		
形状尺寸图 Applicable Fig. No.		Fig.2	Fig.1	Fig.1	Fig.2	Fig.2	Fig.2	Fig.3		
引线直径 Dia. of lead	φd	0.5		0.6			0.8		±0.05	
主体高度 Height of body	L	13.0		22.0		30.0		42.0		MAX
主体间距 Distance from center to center of next body	P	12.7			15.0		30.0			±1.0
穿孔间距 Distance from center to center of next driving hole	P0	12.7			15.0		15.0±0.3			±0.2
穿孔与引线间距 Distance between center of driving hole and lead	P1	5.1	3.85	4.6	3.85	5.0	3.75			±0.5
穿孔与主体间距 Distance between center of driving hole and body	P2	6.35				7.5			±1.0	
引线间距 Pitch of lead	F	2.5	5.0	3.5	5.0±0.8		7.5±0.8			+0.8 -0.2
衬纸宽度 Width of mounting tape	W	18.0						±0.3		
胶带宽度 Width of adhesive tape	W0	5.0				MIN				
穿孔与衬纸间距 Distance between center of driving hole and mounting tape edge	W1	9.0				±0.5				
胶带与衬纸间距 Max. allowable distance between mounting and adhesive tape edges	W2	1.5				MAX				
主体下方位置 Distance between center of driving hole and bottom of body	H	18.5		20.0		18.5 ^{+0.75} _{-0.5}			±0.75	
引线弯曲高度 Distance between center of driving hole and clinch part of lead	H0	—	16.0		—	—			±0.5	
引线头 End of lead	L1	0.5				MAX				
穿孔直径 Dia. of driving hole	φD0	4.0				±0.2				
主体倾斜度 Off alignment of body top	△h	1.0				MAX				
主体倾斜度 Off alignment of body top	△p	1.0				MAX				
编带总厚度 Sum of thickness for mounting and adhesive tape without lead dia	t	0.6				±0.3				
包装数量(个) Quantity (pcs)		2000		1000		500		250		

※允许差有特别规定时，特别规定优先。

For the case that tolerance is specified individually, the value shall have the priority.

◆引线加工规格 / LEAD CUTTING FORMING SPECIFICATIONS

为了使产品在印刷电路板上安装方便，我公司对产品引线有以下加工类型：引线成型，引线切脚，基板自立型特殊加工(爪式引线成型)。

Rubycon provides lead-formed and lead-cut products to facilitate mounting on printed circuit boards, as well as products with leads specially processed (kink formed) for self supporting insertions to printed circuit boards.

•引线成型
Lead forming
($\phi 5 \sim \phi 8$)
Lead forming code : FA

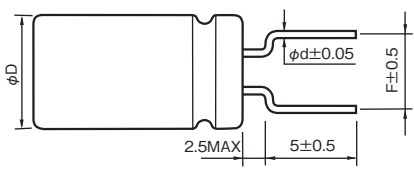

(mm)			
ϕD	5	6.3	8
ϕd	0.5		0.6
F	5.0		

•引线切脚
Lead cutting
($\phi 5 \sim \phi 18$)
Lead cutting code : CA
CC
CE

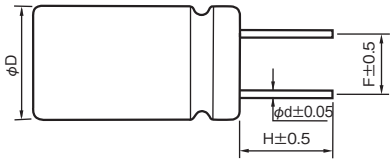

(mm)								
ϕD	5	6.3	8	10	12.5	14.5	16	18
H	5.0 (CA) 4.0 (CC) 3.5 (CE)							
ϕd	0.5		0.6		0.8			
F	2.0	2.5	3.5	5.0		7.5		

•爪式引线成型
Kinked lead forming
($\phi 5 \sim \phi 8$)
Kinked lead forming code : KC

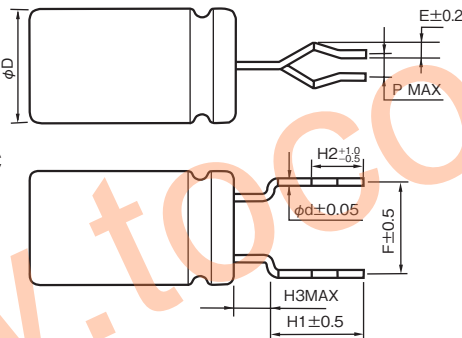

(mm)								
ϕD	5	6.3	8	10	12.5	14.5	16	18
H1	4.5							
H2	2.8							
H3	2.5		—					
F	5.0				7.5			
P	1.0							
E	1.2			1.3				
ϕd	0.5		0.6		0.8			

•爪式引线切脚
Kinked lead cutting
($\phi 10 \sim \phi 18$)
Kinked lead cutting code : KC

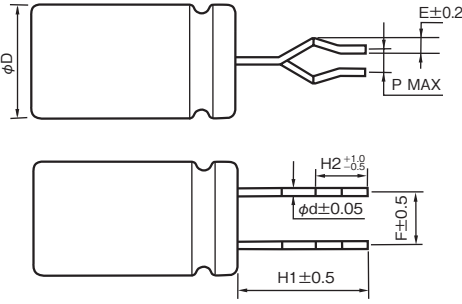

•横置对应品 ($\phi 10 \sim \phi 18$) / Low profile with horizontal mounting

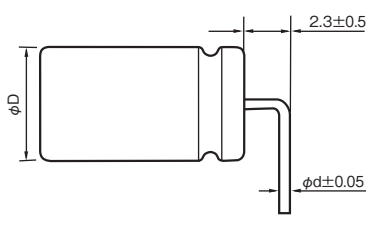

A型 Type A B型 Type B

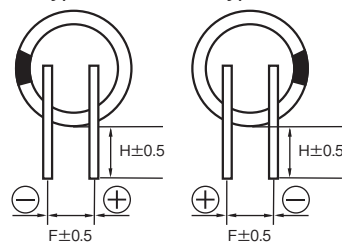

(mm)								
ϕD	10, 12.5				14.5, 16, 18			
Code	RI	RK	RX	SG	RI	RK	RX	SG
ϕd	0.6				0.8			
F	5.0				7.5			
H	4.0		3.5		4.0		3.5	
Type	A	B	A	B	A	B	A	B